

MB 14 ON HOOKLIFT CRADLE – SPECIAL EQUIPMENT

EDIT 270121

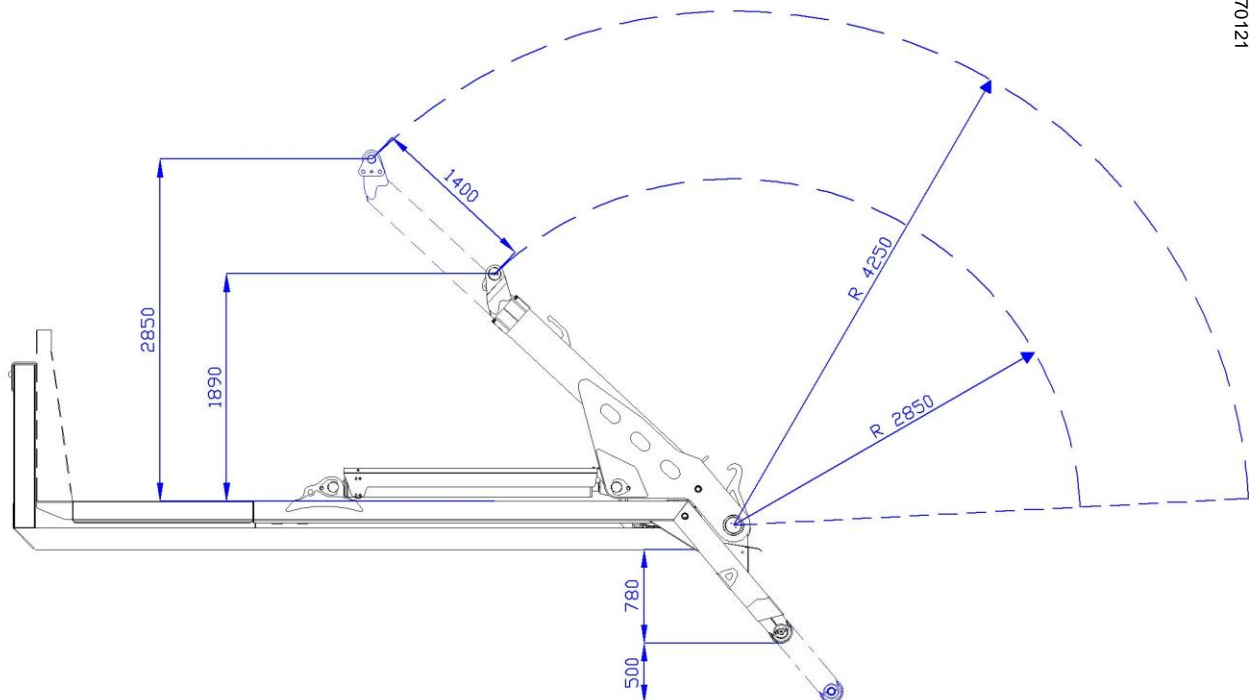

Standard features

- Twin telescopic arms run mm 1.400
- **L1:** Lifting capacity at ground level ton 14
- **L2:** Lifting cap. extended arms tons 9
- **L3:** Lifting cap. 800 mm under the ground level ton 9
- **L4:** Lifting cap. 800 mm under the ground level with extended arms ton 5,5
- No. 4 flow controls with ground hand levers
- Rear independent stabilizing feet
- Tipping hooks with ground control
- Adjustable platform wedges
- Painting in bottom antirust red or grey chassis colour
- Operating manual and spare parts book
- Basic equipment weight: kg 4.000 ca.*
- No. 4 adjustable chains with safety hook locks
- Hoisting cylinders rods protection carter

* The weight is indicative and referred to the basic skip loader without options, accessories and ancillary equipments (platform extension, front cab protection, cylinders protection carter, rear headstock protection carter, etc.)

Options

- Front cab protection panel
- Front platform extension
- Mechanical security on tipping hook (DIN 30720)
- Independent sliding arms
- Radio remote control BOBEASY
- Regenerating oil system (double speed)
- Arms connecting bar
- Electro-pneumatic cab control on mobile hand-board
- Monitoring led arms in resting position
- Monitoring led for stabilizing feet
- Signalling of tipping hooks position
- Rear lights integrated in the headstock carter

The technical details shown in this sheet are indicative and can be changed by the builder without prior notice.

B.O.B. Sistemi Idraulici S.p.A. Regione Oltre Rea, 32 - 12060 Monchiero (CN) Italy
P.I. 00496180043 - ph. +39 0173 780 002/3 Fax +39 0173 780 004 - E-mail info@bobspa.com - web www.bobspa.com



lift your life



Caratteristiche tecniche	Opzioni
<ul style="list-style-type: none"> • Bracci telescopici gemellati sfilo mm 1.400 • L1: Capacità di sollevamento da terra ton 14 • L2: Cap. sollevamento bracci estesi ton 9 • L3: Cap. sollevamento 800 mm sotto livello ton 9 • L4: Cap. sollevamento 800 mm sotto livello con bracci estesi ton 5,5 • No. 4 elementi di comando con leve a terra • Stabilizzatori posteriori indipendenti • Ganci di ribaltamento con controlli a terra • No. 4 catene regolabili con gancio di sicurezza • Cunei piattaforma regolabile • Verniciatura colore telaio antiruggine rosso o grigio • Manuale uso e manutenzione e elenco ricambi • Peso base attrezzatura: kg 4.000 ca.* <p><i>* Il peso è indicativo e si riferisce alla multibenna senza opzioni e accessori</i></p>	<ul style="list-style-type: none"> • Pannello frontale di protezione cabina • Estensione piattaforma frontale • Sicurezza meccanica sul gancio di ribaltamento (DIN 30720) • Bracci indipendenti • BOBEASY telecomando radio • Protezione cilindri di sollevamento • Sistema rigenerativo olio (doppia velocità) • Barra connessione bracci • Comandi elettro-pneumatici in cabina su pulsantiera mobile • Led monitoraggio bracci in posizione di riposo • Monitoraggio per piedi stabilizzatori • Segnalazione posizione ganci di ribaltamento • Luci posteriori integrati nel carter testata posteriore

Caractéristiques techniques	Options
<ul style="list-style-type: none"> • Bras télescopiques jumelés prolongement mm 1.400 • L1: Capacité de levage à terre ton 14 • L2: Cap. levage bras tendu ton 9 • L3: Cap. levage 800 mm inférieur ton 9 • L4: Cap. levage 800 mm inférieur avec bras tendu ton 5,5 • No. 4 éléments de commande avec contrôle à terre • Stabilisateur arrière indépendant • Crochet de basculement avec contrôle à terre • No. 4 chaînes réglables avec crochet de sécurité • Coins de plateforme ajustables • Peinture en apprêt couleur du châssis rouge ou gris • Manuel des opérations, entretien et pièces détachées • Poids de base d'équipement : kg 4.000 ca.* <p><i>* le poids est indicatif et se réfère à Multibennes sans options et accessoires</i></p>	<ul style="list-style-type: none"> • Panneau frontal de la protection cabine • Extension frontal de la plateforme • Sécurité mécanique sur le crochet de basculement (DIN 30720) • Bras coulissants indépendants • BOBEASY radio contrôle • Témoin pour cylindre de bennage • Système de régénération d'huile (double vitesse) • Barre connexion bras • Commandes électropneumatiques en cabine avec manipulateur mobile • Bras de moniteur LED en phase de repos • Témoin pour pied stabilisateur • Signalisation de position des crochets de basculement • Feux arrière intégrés dans le carter arrière

Technische Eigenschaften	Zubehör
<ul style="list-style-type: none"> • Doppelte Teleskoparme Bewegung mm 1.400 • L1: Hubkapazität bei Bodenaufnahme 14 • L2: Hubkapazität bei ausgefahrenen Armen 9 t • L3: Hubkapazität bei 800 mm Grube 9 t • L4: Hubkapazität bei 800 mm Grube mit ausgefahrenen Armen 5,5 t • 4 Kontrollelemente mit Bedienung vom Boden • Hintere unabhängige Abstützfüße • Kipphaken mit Bodensteuerung • 4 verstellbare Ketten mit Sicherheitsverschluss • Verstellbare Keile auf der Rampe • Lackierung in Rostschutzfarbe rot oder Fahrgestellfarbe grau • Bedienungsanleitung und Ersatzteilliste • Gewicht Grundausstattung: kg 4.000 ca.* <p><i>* Das Gewicht ist eine ungefähre Angabe und bezieht sich auf die Grundausstattung des Absetzkippers, ohne Zubehör und zusätzliche Ausstattungen</i></p>	<ul style="list-style-type: none"> • Vorderer Kabinenschutz • Vordere Rampenverlängerung • Mechanische Kipphakensicherung (DIN 30720) • Unabhängige Schiebearme • BOBEASY Funk Fernbedienen • Schutzabdeckung für Hubzylinderstange • Ölregenerierung (doppelte Geschwindigkeit) • Verbindungsstange für Doppelarme • Elektropneumatische Kabinenkontrolle vom mobilen Schaltpult • LED-Überwachung für Arme in Ruhestellung • LED-Überwachung für Abstützfüße • Positionsanzeige für Kipphaken • Rücklichter in die hintere Abdeckung integriert

The technical details shown in this sheet are indicative and can be changed by the builder without prior notice.

B.O.B. Sistemi Idraulici S.p.A. Regione Oltre Rea, 32 - 12060 Monchiero (CN) Italy
P.I. 00496180043 - ph. +39 0173 780 002/3 Fax +39 0173 780 004 - E-mail info@bobspa.com - web www.bobspa.com

