

## MB 16 FIXED ARMS

EDIT 270121

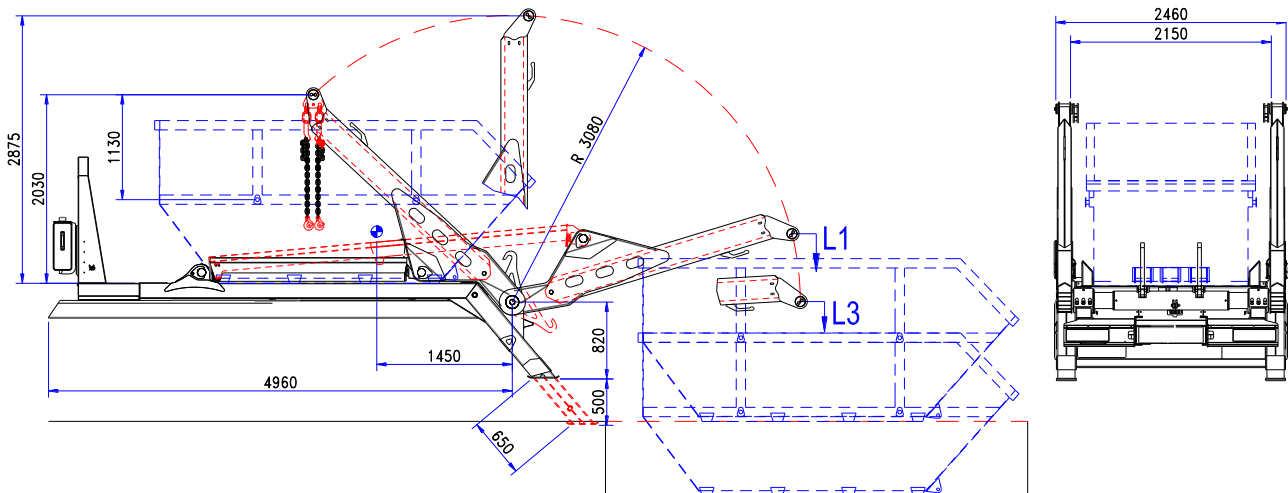

### Standard features

- Fixed twin arms
- **L1:** Lifting capacity at ground level ton 16
- **L3:** Lifting cap. 800 mm under the ground level ton 11
- No. 3 flow controls with ground hand levers
- Rear independent stabilizing feet
- Tipping hooks with ground control
- Front oil tank with support frame
- Adjustable platform wedges
- Integrated subframe H 200 mm
- No. 4 adjustable chains with safety hook locks
- Painting in bottom antirust red or grey chassis colour Operating manual and spare parts book
- Basic equipment weight: kg 3.200 ca.\*

\* The weight is indicative and referred to the basic skip loader without options, accessories and ancillary equipments (platform extension, front cab protection, cylinders protection carter, rear headstock protection carter, etc.)

### Options

- Front cab protection panel
- Front platform extension
- Mechanical security on tipping hook (DIN 30720)
- Landing feet rollers
- Hoisting cylinders rods protection carter
- Regenerating oil system (double speed)
- Arms connecting bar
- Electro-pneumatic cab control on mobile hand-board
- BOBEASY radio control
- Monitoring led arms in resting position
- Monitoring led for stabilizing feet
- Visual or sonorous signalling of tipping hooks position
- Rear lights integrated in the headstock carter

The technical details shown in this sheet are indicative and can be changed by the builder without prior notice.

B.O.B. Sistemi Idraulici S.p.A. Regione Oltre Rea, 32 - 12060 Monchiero (CN) Italy  
 P.I. 00496180043 - ph. +39 0173 780 002/3 Fax +39 0173 780 004 - E-mail [info@bobspa.com](mailto:info@bobspa.com) - web [www.bobspa.com](http://www.bobspa.com)



lift your life



<p style="text-align: center;"><b>Caratteristiche tecniche</b></p> <ul style="list-style-type: none"> <li>• Bracci fissi gemellati</li> <li>• <b>L1:</b> Capacità di sollevamento da terra ton 16</li> <li>• <b>L3:</b> Lifting cap. 800 mm sotto livello ton 11</li> <li>• No. 3 elementi di comando con leva a terra</li> <li>• Stabilizzatori posteriori indipendenti</li> <li>• Ganci di ribaltamento con controlli a terra</li> <li>• Serbatoio frontale con supporto</li> <li>• Controtelaio integrato H 200 mm</li> <li>• No. 4 catene regolabili con gancio di sicurezza</li> <li>• Cunei piattaforma regolabile</li> <li>• Verniciatura colore telaio antiruggine rosso o grigio</li> <li>• Manuale uso e manutenzione e elenco ricambi</li> <li>• Peso base attrezzatura: kg 3.200 ca.*</li> </ul> <p><i>* Il peso è indicativo e si riferisce alla multibenna base senza opzioni e accessori</i></p>	<p style="text-align: center;"><b>Opzioni</b></p> <ul style="list-style-type: none"> <li>• Pannello frontale di protezione cabina</li> <li>• Estensione piattaforma frontale</li> <li>• Sicurezza meccanica sul gancio di ribaltamento (DIN 30720)</li> <li>• Stabilizzatori su rulli</li> <li>• Protezione stelo cilindri di sollevamento</li> <li>• Sistema rigenerativo olio (doppia velocità)</li> <li>• BOBEASY telecomando radio</li> <li>• Barra connessione bracci</li> <li>• Comandi elettro-pneumatici cabina su pulsantiera mobile</li> <li>• Led monitoraggio bracci in posizione di riposo</li> <li>• Monitoraggio per piedi stabilizzatori</li> <li>• Segnalazione visiva e sonora posizione ganci di ribaltamento</li> <li>• Luci posteriori integrati nel carter testata posteriore</li> </ul>
<p style="text-align: center;"><b>Caractéristiques techniques</b></p> <ul style="list-style-type: none"> <li>• Bras fixés jumelés</li> <li>• <b>L1:</b> Capacité de bennage à terre ton 16</li> <li>• <b>L3:</b> Levage cap. 800 mm inférieur ton 11</li> <li>• No. 3 éléments de commande avec contrôle à terre</li> <li>• Stabilisateurs arrière indépendants</li> <li>• Crochet de bennage avec contrôle à terre</li> <li>• Réservoir frontal avec support</li> <li>• Coins de plateforme ajustables</li> <li>• Châssis intégré H 200 mm</li> <li>• No. 4 chaînes réglables avec crochet de sécurité</li> <li>• Peinture antirouille couleur du châssis rouge ou gris</li> <li>• Manuel des opérations, entretien et pièces détachées</li> <li>• Poids de base de l'équipement kg 3.200 ca.*</li> </ul> <p><i>* le poids est indicatif et se réfère sur la base de la Multibennes sans options et accessoires</i></p>	<p style="text-align: center;"><b>Options</b></p> <ul style="list-style-type: none"> <li>• Panneau frontal protection cabine</li> <li>• Extension frontale de la plateforme</li> <li>• Sécurité mécanique sur crochet de basculement (DIN 30720)</li> <li>• Stabilisateurs sur rouleaux</li> <li>• Carter de protection des tiges des vérins de bennage</li> <li>• Système de régénération d'huile (double vitesse)</li> <li>• BOBEASY radio contrôle</li> <li>• Témoin vérins de bennage</li> <li>• Barre connexion bras</li> <li>• Commande en cabine avec manipulateur mobile</li> <li>• Moniteur bras en phase de repos</li> <li>• Témoin pour pied stabilisateur</li> <li>• Signalisation de position des crochets de basculement</li> <li>• Feux arrière intégrés dans le carter arrière</li> </ul>
<p style="text-align: center;"><b>Technische Eigenschaften</b></p> <ul style="list-style-type: none"> <li>• Feste Doppelarme</li> <li>• <b>L1:</b> Hubkapazität bei Bodenaufnahme 16 t</li> <li>• <b>L3:</b> Hubkapazität bei 800 mm Grube 11 t</li> <li>• 3 Kontrollelemente mit Bedienung vom Boden</li> <li>• Hintere unabhängige Abstützfüße</li> <li>• Kippheben mit Bodensteuerung</li> <li>• Vorderer Öltank mit Befestigungsrahmen</li> <li>• Verstellbare Keile auf der Rampe</li> <li>• Integrierter Hilfsrahmen H 200 mm</li> <li>• 4 verstellbare Ketten mit Sicherheitsverschluss</li> <li>• Lackierung in Rostschutzfarbe rot oder Fahrgestellfarbe grau</li> <li>• Bedienungsanleitung und Ersatzteilliste</li> <li>• Gewicht Grundausstattung: kg 3.200 ca.*</li> </ul> <p><i>* Das Gewicht ist eine ungefähre Angabe und bezieht sich auf die Grundausstattung des Absetzkippers, ohne Zubehör und zusätzliche Ausstattungen</i></p>	<p style="text-align: center;"><b>Zubehör</b></p> <ul style="list-style-type: none"> <li>• Vorderer Kabinenschutz</li> <li>• Vordere Rampenverlängerung</li> <li>• Mechanische Kipphebensicherung (DIN 30720)</li> <li>• Rollstützfüße</li> <li>• Schutzabdeckung für Hubzylinderstange</li> <li>• Ölregenerierung (doppelte Geschwindigkeit)</li> <li>• BOBEASY Funk Fernbedienung</li> <li>• Verbindungsstange für Doppelarme</li> <li>• Elektropneumatische Kabinensteuerung mit mobilem Schaltkasten</li> <li>• LED-Überwachung für Arme in Ruhestellung</li> <li>• LED-Überwachung für Abstützfüße</li> <li>• Optisches oder Tonsignal der Kipphebenposition</li> <li>• Rücklichter in die hintere Abdeckung integriert</li> </ul>

The technical details shown in this sheet are indicative and can be changed by the builder without prior notice.

B.O.B. Sistemi Idraulici S.p.A. Regione Oltre Rea, 32 - 12060 Monchiero (CN) Italy  
P.I. 00496180043 - ph. +39 0173 780 002/3 Fax +39 0173 780 004 - E-mail [info@bobspa.com](mailto:info@bobspa.com) - web [www.bobspa.com](http://www.bobspa.com)



## MB 16 TELESCOPIC ARMS

EDIT 270121

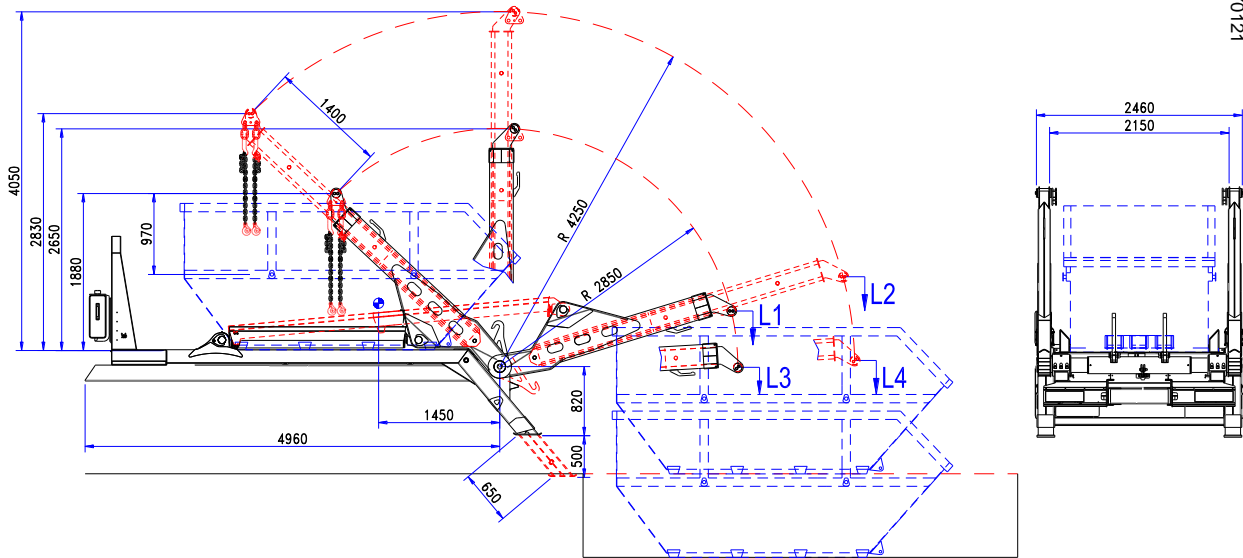

### Standard features

- Twin telescopic arms run mm 1.400
- **L1:** Lifting capacity at ground level ton 16
- **L2:** Lifting cap. with extended arms tons 11
- **L3:** Lifting cap. 800 mm under the ground level ton 11
- **L4:** Lifting cap. 800 mm under the ground level with extended arms ton 7
- Integrated subframe H 200 mm
- No. 4 flow controls with ground hand levers
- Rear independent stabilizing feet
- Tipping hooks with ground control
- Front oil tank with support frame
- Adjustable platform wedges
- Painting in bottom antirust red or grey chassis colour
- Operating manual and spare parts book
- No. 4 adjustable chains with safety hook locks
- Basic equipment weight: kg 3.450 ca.\*

\* The weight is indicative and referred to the basic skip loader without options, accessories and ancillary equipments (platform extension, front cab protection, cylinders protection carter, rear headstock protection carter, etc.)

### Options

- Front cab protection panel
- Front platform extension
- Mechanical security on tipping hook (DIN 30720)
- Landing feet rollers
- Independent sliding arms
- Hoisting cylinders rods protection carter
- Regenerating oil system (double speed)
- Arms connecting bar
- Electro-pneumatic cab control on mobile hand-board
- BOBeasy remote radio control
- Monitoring led arms in resting position
- Monitoring led for stabilizing feet
- Visual or sonorous signalling of tipping hooks position
- Rear lights integrated in the headstock carter

The technical details shown in this sheet are indicative and can be changed by the builder without prior notice.

B.O.B. Sistemi Idraulici S.p.A. Regione Oltre Rea, 32 - 12060 Monchiero (CN) Italy  
P.I. 00496180043 - ph. +39 0173 780 002/3 Fax +39 0173 780 004 - E-mail [info@bobspa.com](mailto:info@bobspa.com) - web [www.bobspa.com](http://www.bobspa.com)



lift your life



<p style="text-align: center;"><b>Caratteristiche tecniche</b></p> <ul style="list-style-type: none"> <li>• Bracci telescopici gemellati sfilo mm 1.400</li> <li>• <b>L1:</b> Capacità di sollevamento da terra ton 16</li> <li>• <b>L2:</b> Lifting cap. con bracci estesi ton 11</li> <li>• <b>L3:</b> Lifting cap. 800 mm sotto livello ton 11</li> <li>• <b>L4:</b> Lifting cap. 800 mm sotto livello con bracci estesi ton 7</li> <li>• No. 4 elementi di comando con leve a terra</li> <li>• Stabilizzatori posteriori indipendenti</li> <li>• Ganci di ribaltamento con controlli a terra</li> <li>• Serbatoio frontale con supporto</li> <li>• Controtelaio integrato H 200 mm</li> <li>• No. 4 catene regolabili con gancio di sicurezza</li> <li>• Cunei piattaforma regolabile</li> <li>• Verniciatura colore telaio antiruggine rosso o grigio</li> <li>• Manuale uso e manutenzione e elenco ricambi</li> <li>• Peso base attrezzatura: kg 3.450 ca.*</li> </ul> <p><i>* Il peso indicativo si riferisce alla multibenna senza opzioni e accessori</i></p>	<p style="text-align: center;"><b>Opzioni</b></p> <ul style="list-style-type: none"> <li>• Pannello frontale di protezione cambia</li> <li>• Estensione piattaforma frontale</li> <li>• Sicurezza meccanica sul gancio di ribaltamento (DIN 30720)</li> <li>• Stabilizzatori su rulli</li> <li>• Bracci indipendenti</li> <li>• BOBEASY telecomando radio</li> <li>• Protezione cilindri di sollevamento</li> <li>• Sistema rigenerativo olio (doppia velocità)</li> <li>• Barra connessione bracci</li> <li>• Comandi elettro-pneumatici cabina su pulsantiera mobile</li> <li>• Led monitoraggio bracci in posizione di riposo</li> <li>• Monitoring led arms in resting position</li> <li>• Monitoraggio per piedi stabilizzatori</li> <li>• Segnalazione visiva e sonora posizione ganci di ribaltamento</li> <li>• Luci posteriori integrati nel carter testata posteriore</li> </ul>
<p style="text-align: center;"><b>Caractéristiques techniques</b></p> <ul style="list-style-type: none"> <li>• Bras télescopiques jumelés prolongement mm 1.400</li> <li>• <b>L1:</b> capacité de bennage à terre ton 16</li> <li>• <b>L2:</b> levage cap. Avec bras tendu ton 11</li> <li>• <b>L3:levage</b> cap. 800 mm inférieur ton 11</li> <li>• <b>L4:</b> levage cap. 800 mm inferieur avec bras tendu ton 7</li> <li>• No. 4 éléments de commande avec contrôle à terre</li> <li>• Stabilisateur arrière indépendant</li> <li>• Crochet de basculement avec contrôle à terre</li> <li>• Châssis intégré H 200 mm</li> <li>• No. 4 chaînes réglables avec crochet de sécurité</li> <li>• Réservoir frontal avec support</li> <li>• Coins de plateforme ajustables</li> <li>• Peinture en apprêt couleur du châssis rouge ou gris</li> <li>• Manuel des opérations, entretien et pièces détachées</li> <li>• Peso base attrezzatura: kg 3.450 ca.*</li> </ul> <p><i>* le poids est indicatif et se réfère sur la base de la Multibennes sans options et accessoires</i></p>	<p style="text-align: center;"><b>Options</b></p> <ul style="list-style-type: none"> <li>• Panneau frontal protection cabine</li> <li>• Extension frontale de la plateforme</li> <li>• Sécurité mécanique sur le crochet de basculement (DIN 30720)</li> <li>• Stabilisateur sur rouleaux</li> <li>• Bras coulissants indépendants</li> <li>• BOBEASY radio contrôle</li> <li>• Témoin pour cylindre de bennage</li> <li>• Système de régénération d'huile (double vitesse))</li> <li>• Barre connexion bras</li> <li>• Commandes électropneumatiques en cabine avec manipulateur mobile</li> <li>• Bras de moniteur LED en phase de repos</li> <li>• Monitoring led arms in resting position</li> <li>• Témoin pour pied stabilisateur</li> <li>• Signal visuel et bruyant : position du crochet de basculement</li> <li>• Feux arrière intégrés dans le carter arrière</li> </ul>
<p style="text-align: center;"><b>Technische Eigenschaften</b></p> <ul style="list-style-type: none"> <li>• Doppelte Teleskoparmen Bewegung mm 1.400</li> <li>• <b>L1:</b> Hubkapazität bei Bodenaufnahme 16 t</li> <li>• <b>L2:</b> Hubkapazität mit ausgefahrenen Armen 11 t</li> <li>• <b>L3:</b> Hubkapazität bei 800 mm Grube 11 t</li> <li>• <b>L4:</b> Hubkapazität bei 800 mm Grube mit ausgefahrenen Armen 7 t</li> <li>• 4 Kontrollelemente mit Bedienung vom Boden</li> <li>• Hintere unabhängige Abstützfüße</li> <li>• Kipphebel mit Bodensteuerung</li> <li>• Vorderer Öltank mit Befestigungsrahmen</li> <li>• Verstellbare Keile auf der Rampe</li> <li>• Integrierter Hilfsrahmen H 200 mm</li> <li>• 4 Stck. verstellbare Ketten mit Sicherheitsverschluss</li> <li>• Lackierung in Rostschutzfarbe rot oder Fahrgestellfarbe grau</li> <li>• Bedienungsanleitung und Ersatzteilliste</li> <li>• Gewicht Grundausstattung: kg 3.450 ca.*</li> </ul> <p><i>* Das Gewicht ist eine ungefähre Angabe und bezieht sich auf die Grundausstattung des Absetzkippers</i></p>	<p style="text-align: center;"><b>Zubehör</b></p> <ul style="list-style-type: none"> <li>• Vorderer Kabinenschutz</li> <li>• Vordere Rampenverlängerung</li> <li>• Mechanische Kipphebelverriegelung (DIN 30720)</li> <li>• Rollstützfüße</li> <li>• Unabhängige Schiebearme</li> <li>• BOBEASY Funk Fernbedienung</li> <li>• Schutzabdeckung für Hubzylinderstange</li> <li>• Ölregenerierung (doppelte Geschwindigkeit)</li> <li>• Verbindungsstange für Doppelarme</li> <li>• Elektropneumatische Kabinensteuerung mit mobilem Schaltkasten</li> <li>• LED-Überwachung für Arme in Ruhestellung</li> <li>• LED-Überwachung für Abstützfüße</li> <li>• Optisches oder Tonsignal der Kipphebelposition</li> <li>• Rücklichter in die hintere Abdeckung integriert</li> </ul>

The technical details shown in this sheet are indicative and can be changed by the builder without prior notice.

B.O.B. Sistemi Idraulici S.p.A. Regione Oltre Rea, 32 - 12060 Monchiero (CN) Italy  
P.I. 00496180043 - ph. +39 0173 780 002/3 Fax +39 0173 780 004 - E-mail [info@bobspa.com](mailto:info@bobspa.com) - web [www.bobspa.com](http://www.bobspa.com)





*lift your life*



---

The technical details shown in this sheet are indicative and can be changed by the builder without prior notice.

B.O.B. Sistemi Idraulici S.p.A. Regione Oltre Rea, 32 - 12060 Monchiero (CN) Italy  
P.I. 00496180043 - ph. +39 0173 780 002/3 Fax +39 0173 780 004 - E-mail [info@bobspa.com](mailto:info@bobspa.com) - web [www.bobspa.com](http://www.bobspa.com)

**bob italev**

**bob ampliner**

***ITRunner***

**bob unilift**

**bob itranner**